

Stok Donut Robot

The MP2 donut and MP3 mini donut-making machines represent incredibly good value and are the top of the line professional automatic donut-making machines.



Here are a few reasons why our clients prefer our donut machines:

- Our machines meet the highest safety and food-processing sanitary standards
- The MP2 and MP3 automatic donut making machines have been granted CE certificates by an independent EU-Approved Test Laboratory
- The CE testing proves the correctness of the build and safety, particularly important for deep frying machines
- The donut machines are both guaranteed for a full year with warranty; there is also an extended service and repair option

Stok Donut Robot

- The machines are fully-automatic and have electronic controls that allow adjustment of the frying time and frying temperature
- Both the MP2 and MP3 machines are made of 100% high-quality stainless steel
- The frying reservoir has a capacity of 20 liters, allowing the uninterrupted production of donuts during busy periods of operation
- The two powerful heaters deliver 4,000 watts of heat to the oil, enabling a fast start-up and keeping the oil at the correct frying temperature of 190° C, even at freezing ambient temperatures
- The electronic controls include two donut counters so that donut production can be measured against income and raw materials used
- The cleaning procedure for both the MP2 and MP3 is simple and fast: the chain drive is removed in under five seconds and to change the oil simply turn the tap and let it flow out for recycling
- We offer the highest quality of donut premix: consistently superb donut taste makes your customers come back for more donuts, helping your business become even more successful

MP3 – Mini-Donuts Machine

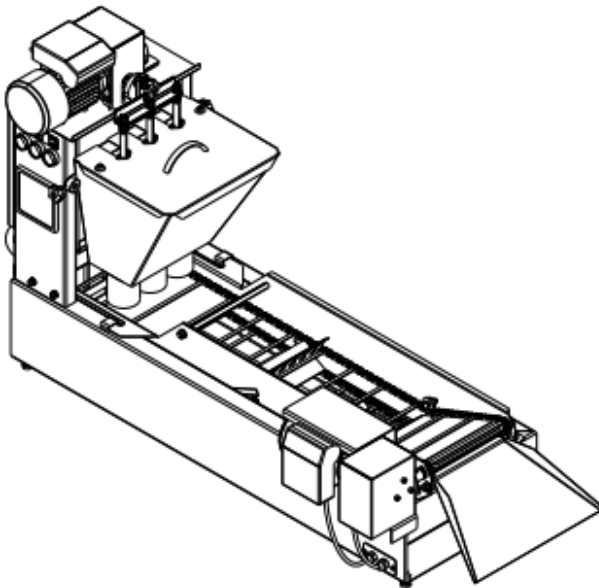

MP2-1 / MP2-2 – Big / Regular Donut Machine

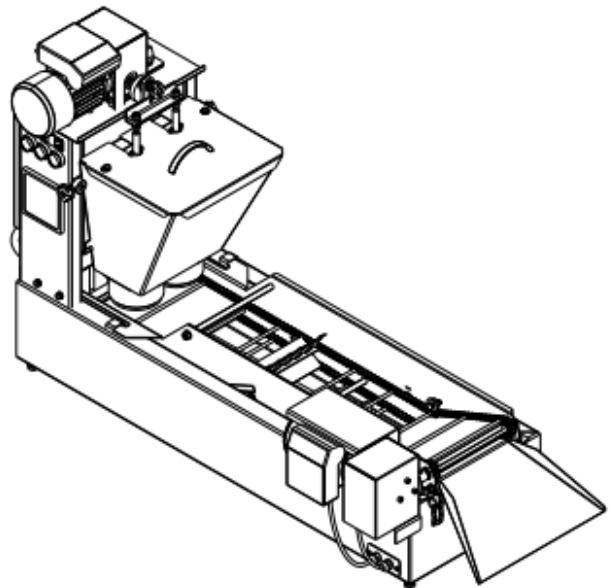





The MP3 machine produces mini donuts (20 grams each), the MP2-1 produces big donuts (40 grams) and the MP2-2 produces regular donuts (30 grams). MP3 can make up 1200 donuts per hour, while MP2-1 and MP2-2 can make up to 600 per hour (bigger donuts require longer frying time). The difference between all machines is in the number of nozzles for dropping donuts (3 for MP3 vs 2 for MP2), size of the nozzles for the corresponding donut size, and the chain that moves the donuts (there is a difference in the space between the rods on the chain).

Stok Donut Robot

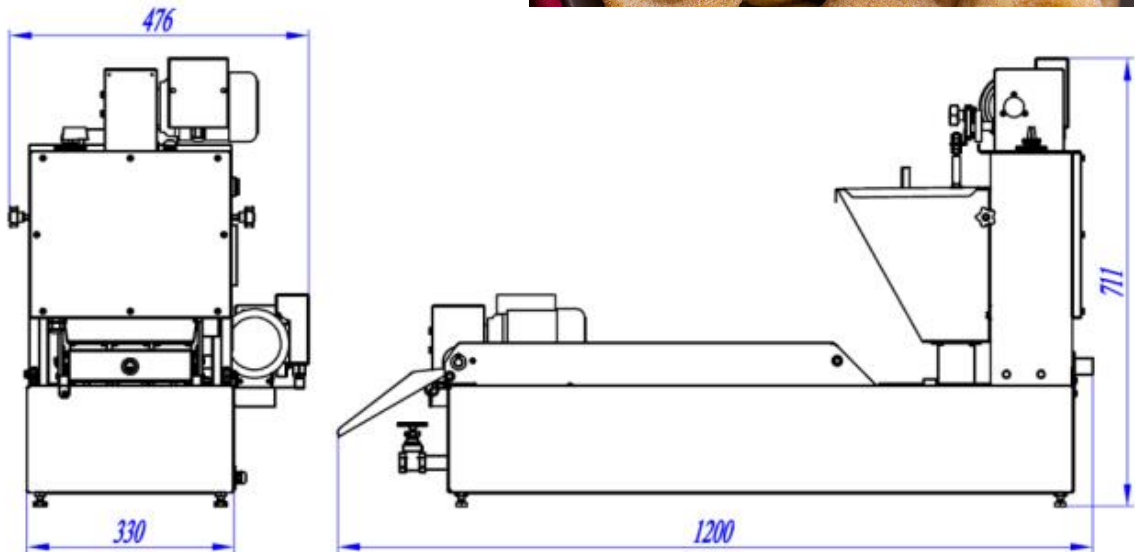

Dimensions of Both MP2 and MP3
(in mm)



Technical Specifications			
	MP2-1 Big-Donut Machine	MP2-2 Regular-Donut Machine	MP3 Mini-Donut Machine
			
Donut Size & Weight	9 centimeters, 40 grams	7 centimeters, 30 grams	5 centimeters, 20 grams
Maximum Productivity	600 donuts per hour		1200 donuts per hour
Max Power	4 kW		
Frying Reservoir	20 liters		
Dough Dispenser Capacity	8 liters		
Weight (empty)	61 kg		
Power Source	220V/50Hz or 110V/60Hz option		